

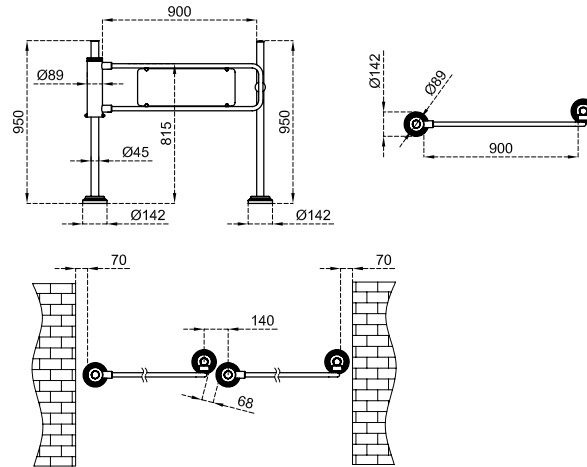

Dimensions (mm)



Technical Features

Place of Use	Indoors, outdoors (with wing adaptation)
Operating Intensity	%100, 7/24 use.
Body Features	Material : Ø89x3 mm 304 grade stainless steel. Finishing : Satine brushed (opt. orbital brushed matt, electrostatic powder coating on stainless steel).
Wing	Material : Ø27x2 mm 304 grade stainless steel pipe with acrylic infill. Finishing : Satine brushed (opt. orbital brushed matt, electrostatic powder coating on stainless steel).
Power	Operating Voltage : No power for standard model (opt. 24V DC (250mA) for 35 kg electromagnetic lock).
Operating Mode	System operates uni-directionally (clockwise or counter clockwise). Wing, opening 90° by pushing comes back to its original position thanks to the spring system ensuring the closing of the wing.
Operating System	Mechanical manual operation.
Emergency Mode	Electromagnetic lock (if any) is deactivated during the emergency contact, and the wing is pushed manually to create a free passageway.
Power-off Situation	Electromagnetic lock (if any) becomes disabled, and the wing is pushed manually to create a free passageway.
Weight	~15 kg
Optional Features and Accessories	Electromagnetic lock, wireless remote control (receiver-transmitter, with electromagnetic lock option), manual control (with electromagnatic lock option), key lock pole, bottom plate, electrostatic powder coating on stainless steel.